

ELECTRIC TOW TRACTOR FLOOR-RUNNER

CBT4 & CBT6
8,800 & 13,200 lbs
TOWING CAPACITY

Toyota's CBT4 & CBT6 Floor-Runner models are highly reliable sit-down electric towing tractors designed with the ever increasing demands of your application in mind.



RELIABILITY/DURABILITY

- **48 volt electrical system** for optimal performance in the toughest applications.
- **UL-approved model type E** to meet specific environmental conditions.
- **Helical gears** provide high transmission efficiency and lower noise levels.
- **Hydraulic drum brakes** provide smooth stops while towing heavy loads.
- **Heavy-gauge** unitized steel frame construction.
- **Heavy-duty front bumper** option available for added chassis protection.

TOYOTA INNOVATION

OPERABILITY/PERFORMANCE

- **Transistor control system** offers smooth acceleration and improved battery efficiency.
- **Three-wheel platform and a short wheelbase** provide a tight turning radius for maximum maneuverability and control in confined work environments.
- **Cargo rack** allows operators to securely place packages onto the rear of the vehicle.
- **Transversely-mounted drive motor** provides excellent power and gradeability.
- **Center pin** mounted front axle provides a smoother ride.
- **Quick release tow hitch** option available to increase comfort and productivity by enabling the operator to release load carts without having to leave the seat.

EASE OF SERVICE

- **Brake fluid reservoir** conveniently mounted inside the operator compartment for quick and accurate daily operator checks.
- **Solid pneumatic dual steer tires** increase tire life while providing the operator with a smoother ride.
- **Low-effort battery hood** features a convenient handle and an assist damper that automatically holds the hood open for easy battery access.

ERGONOMICS

- **Ergonomically designed operator's compartment** allows easy operation of all controls and pedals to help reduce operator fatigue.
- **Electric shift lever** offers fingertip control for fast and easy direction changes.
- **Fore/aft adjustable seat** and spacious legroom improve overall operator comfort.
- **Low step height** allows for easy entry and exit.
- **Small-diameter steering wheel** with a two-stage reduction unit provides effortless steering.
- **Tilt steering column** option available to further improve ergonomics and comfort.



TYPICAL APPLICATIONS

- Towing parts and sub-assemblies at manufacturing facilities
- Towing carts at mail distribution centers
- Transporting products at industrial and chemical plants
- General warehousing



OPERATOR COMPARTMENT

- Low step height
- Spacious leg room
- Fore/aft adjustable seat for a wide range of operators
- Ergonomically angled pedals
- Tilt steering column (optional)



INSTRUMENT PANEL

- On/off key switch
- Battery discharge indicator
- Hour meter
- Double action parking brake
- Electric shift lever for forward and reverse
- Seat switch with dedicated hour meter (optional)



CARGO RACK & TOW HITCH

- Cargo rack
- Rear tow hitch (pin and clevis type)
- Quick release tow hitch (optional)
- Fast charge modification (optional)



BATTERY COMPARTMENT

- Battery hood with lift handle and assist damper
- 400 AH (max. capacity)
- Battery roll-out (optional)



LIGHTS, MIRRORS & TIRES

- Solid pneumatic tires
- Recessed headlight
- Operator rear view mirrors (optional)
- Front & rear combination lights (optional)



POWER SYSTEM

- 48 Volt electrical system
- UL-approved model type E
- Transistor control system
- Transversely-mounted drive motor

CBT4 & CBT6 - SPECIFICATIONS

Unit: in

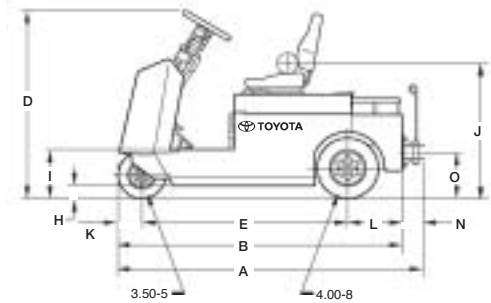
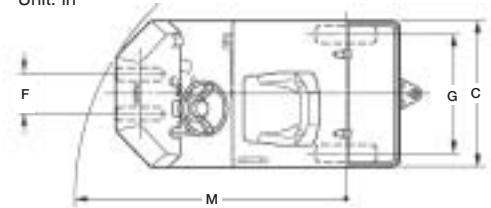

Model	CBT4	CBT6
Towing Capacity	8,800 lbs	13,200 lbs
Drawbar Pull	880 lbs	990 lbs
(A) Overall Length with Tow Hitch		79.5"
(B) Overall Length without Tow Hitch		74"
(C) Overall Width		38"
(D) Overall Height		49.2"
(E) Wheelbase		53.5"
(F) Front Tread		10.2"
(G) Rear Tread		31.1"
(H) Underclearance		3.15"
(I) Operator Platform Height		13"
(J) Seat Height (Floor to Seat Index Point)		34.3"
(K) Front Overhang		6.3"
(L) Rear Overhang		14.2"
(M) Outside Turning Radius		69.9"
(N) Tow Hitch Length		5.5"
(O) Tow Hitch Height		12"
Cargo Rack (LxW)		12"x35.4"
Battery Compartment (LxWxH)	Without Rollers	19.57"x29.33"x23.4"
	With Rollers	19.57"x29.33"x20.6"
Voltage		48V
Maximum Battery Amperage		400 AH
Motor Rating	3.5 hp	6.6 hp
Battery Connector Cable	Without Rollers	C/13.4"
Location/Length	With Rollers	B/7.9"
Battery Connector/Color		SB-175/Red
Travel Speed	With Load	5.6 mph (4400 lbs)
	No Load	8.4 mph (6600 lbs)
Total Weight without Battery		1190 lbs
		1290 lbs

CONTACT YOUR LOCAL DEALER FOR COMPLETE LIST OF OPTIONS & SPECIFICATIONS.

OPTIONS

- Tilt steering column (6° tilt range)
- Fast charge modification (CBT4 only)
- Quick release tow hitch
- Battery roll-out
- Front bumper
- Keyless key switch
- Rear combination lights
- Front combination lights (turn signal lights)
- 4-way hazard lights
- Strobe light wiring
- Seat switch with dedicated hour meter
- Forward and back-up chime
- Rear view mirrors
- Non-marking solid pneumatic tires
- Pneumatic tires
- Document box
- Clipboard
- Pencil holder



Details of specifications and equipment are based on information available at the time of printing and may change without notice.

For more information or the nearest Toyota dealer, call 1-800-226-0009 or visit www.toyotaforklift.com.

00722-35137-903 9/03
Litho in U.S.A. (10M)
©2003 Toyota Material Handling, U.S.A., Inc.