



# 8HBW30

## SPECIFICATIONS

### ELECTRIC WALKIE PALLET TRUCK

Featuring AC Drive System Technology, Toyota's electric pallet trucks offer superior overall performance and reliability. Increased speeds with advanced ergonomics provide higher productivity, optimized operator comfort and efficiency.

### Standard Features

#### PERFORMANCE

- 6,000 lb capacity
- 24-Volt electrical system
- 6" lift
- AC Drive System with thermal protection and current limiting
- Fault code memory with hour meter reading
- Regenerative braking
- Programmable performance parameters
- Multiple hour meter indicator
- Battery discharge indicator with lift interrupt
- Fused control and power circuits
- On/off key switch
- Lift limit switch
- Hydraulic overload protection valve
- Dual lift cylinder design

#### DURABILITY

- Controller Area Network (CAN-bus) communications
- Welded construction with reinforced heavy-duty bumper
- Powder-coat paint finish
- Box rail fork construction
- Steel bulkhead wrappers
- Forged rectangular steel tension rods
- Heavy-duty bushings and pins

- Solid trail fork casting
- Tapered fork tips with pallet entry slides
- Four-point lift linkage
- High-strength polymer service cover
- Rubber drive tire
- Polyurethane load wheels with steel hubs
- Hall-effect switches

#### ERGONOMICS

- Multifunction control handle with ergonomically angled hand grips
- Dual thumb wheels with twist grips for directional control and travel speed
- Fingertip control of lift, lower and horn functions
- Low-effort control handle

#### SERVICEABILITY

- AC drive motor (no brushes or commutator)
- One-piece, lightweight service access cover
- Teflon® Coated Polyube™ lift linkage bushings (maintenance free)
- Error indicator with self-diagnostics

#### SAFETY

- Wrap-around hand guard
- Spring-loaded control handle
- Directional reverse switch on control handle
- Runaway protection

- Side stabilizing steel bars
- Electronic horn

### Optional Equipment

- Battery compartment rollers with dual side gates
- Battery side gates interlock switches
- Various drive tire and load wheels
- Pallet entry/exit rollers
- Cold storage conditioning
- 48", 60" or 72" load backrest extension
- Various fork lengths
- Various overall fork widths
- Amenities tray
- Electronic touch-pad, keyless entry system with password protection
- Power hook-up for on-board terminal
- Keyless on/off switch
- Controller splash guard
- Load wheel debris diversion device
- UL-approved model type E or EE



# 8HBW30 Specifications

## EXTERIOR DIMENSIONS (inches)

<b>A</b> Fork Length	<b>32</b>	<b>36</b>	<b>42</b>	<b>48</b>	<b>60</b>
<b>B</b> Overall Length	63.7	67.7	73.7	79.7	91.7
<b>C</b> Wheelbase – Lowered	46.5	50.5	56.5	62.5	74.5
<b>D</b> Wheelbase – Raised	45.8	45.8	51.8	57.8	69.8
<b>E</b> Turning Radius	51.4	55.4	61.4	67.4	79.4
<b>F</b> Overall Fork Width	22 or 24 or 27				

Gross Weight Without Batteries (lbs)	1000	1014	1036	1058	1108
--------------------------------------	------	------	------	------	------

## BATTERY – 24 VOLT

Amps Max. (Ah)	Standard	510
	Optional	750
Battery Connector/Color	SB-175/Gray	
Battery Connector Cable Location	B	
Battery Connector Cable Length (inches)	18	
Dimensions of Battery Compartment L x W (inches)	Standard	31.5 x 9.20 <sup>(1)</sup>
	Optional	31.5 x 13.44 <sup>(2)</sup>
Battery Weight Max. (lbs)	Standard	1056
	Optional	1500
Battery Weight Min. (lbs)	Standard	490
	Optional	490

## PERFORMANCE

Travel Speed (mph)	Full Load/No Load	3.7/3.7
Gradeability %	Full Load/No Load	10/10

## TIRES

Type	Drive	Rubber
	Load	Polyurethane
Size	Drive – Dia. x Width (inches)	12 x 4.75
	Load – Dia. x Width (inches)	3.25 x 5.91

## aisle requirements – right angle stacking (inches)

Pallet Width	Fork Length				
	32	36	42	48	60
36	65.2	69.2	75.2	81.2	93.2
40	65.2	69.2	75.2	81.2	93.2
42	65.2	69.2	75.2	81.2	93.2
48	65.2	69.2	75.2	81.2	93.2

Minimum Aisle Width for Right Angle Stacking.

Includes 4" clearance each side of load.

Add a minimum of 12" for easy maneuvering.

- (1) 31.25" x 9.20" when equipped with optional battery compartment rollers
- (2) 31.25" x 13.44" when equipped with optional battery compartment rollers

Units: inches

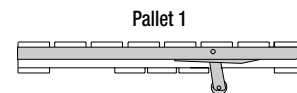
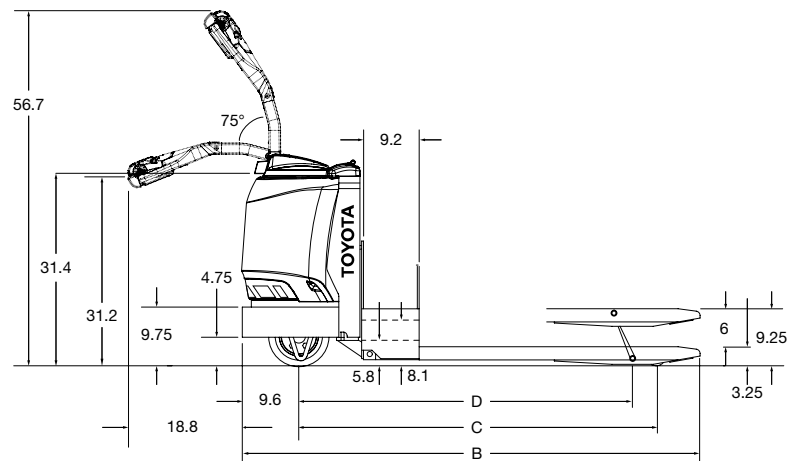
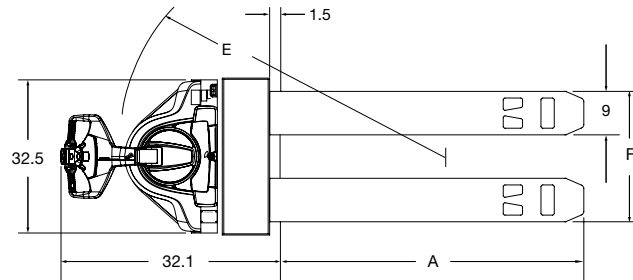

For 32-60 inch long forks



Some product features described herein are optional. Please consult your dealer for specifications. Details of specifications and equipment are based on information available at time of printing and may change without notice.

00722-8S109-607 3/08  
Litho in U.S.A. (6M)

©2008 Toyota Material Handling, U.S.A., Inc.  
www.toyotaforklift.com

