

2TDU25 Diesel Tow Tractor

SPECIFICATIONS



 **TOYOTA**
INDUSTRIAL EQUIPMENT



 **TOYOTA**
INDUSTRIAL EQUIPMENT

00722-2TD11-708
Litho in U.S.A. (1M)
©2008 Toyota Material Handling, U.S.A., Inc.

5,500 lbs Drawbar Pull

PERFORMANCE

- Toyota 1DZ-III, 2.4 liter diesel engine
- UL compliant model type "D"
- 3 speed automatic transmission
- 57,300 lb/72,750 lb towing capacity (2TDU20/25)
- Operator Presence Sensing System (OPSS) (Available 3rd Quarter 2008)
- Sedimeter
- Front disc and rear drum hydraulic brakes
- Hydraulic power steering
- EPA/CARB Interim Tier 4 certified engine
- Front radial, rear bias ply pneumatic tires
- Torque converter oil cooler

ERGONOMICS

- Infinitely adjustable tilt steering wheel
- Low entry step height
- Double action parking brake
- Adjustable seat (fore/aft)
- Morse style gear selector
- Heavy-duty vinyl seat
- Integrated monitoring system with hourmeter, fuel and coolant gauges along with warning indicators

BODY/EXTERIOR DESIGN

- Heavy-gauge steel construction
- Speedometer
- Rear single stage pin type hitch with remote release
- Heavy duty front steel bumper
- Recessed rear combination lights
- Remote hood release
- Easy access service compartments
- Tight turning radius
- Industrial style front and rear suspension/axle

OPTIONAL EQUIPMENT

- Steel cabin with doors
- Steel cabin without door
- Steel cabin accessory option
 - Heater and defroster
 - Center rear view mirrors
 - L & R rear view mirrors
- Turn signal lights
- Rear combination lights
- Back up alarm
- Seat belts
- Co-operator vinyl seat and grab bar
- Yellow beacon
- Left and right rear view mirrors
- Suspension seats
- Two stage rear drawbar pin
- Front tow hitch

2TDU25 Specifications

MAIN VEHICLE SPECIFICATIONS

Manufacturer	TOYOTA
Model	2TDU25

PERFORMANCE

Travel Speed	No load	mph	16
	With one Trailer	lb	72,750
Towed Weight	With two or more	lb	108,000
Maximum Drawbar Pull		lb	5500
Gradeability	Forward, 1st gear	%	46
	Reverse	%	34

DIMENSIONS

A	Overall Length	w/o Tow Hitch	in	110
B	Overall Length	w/ Tow Hitch	in	119
C	Overall Width		in	55.9
D	Overall Height	w/o Cab	in	54.8
E	Overall Height	w/ Cab	in	76.4
F	Drawbar Height	Standard Drawbar	in	17.7
G	Turning Radius (outside)		in	120.2
H	Tread	Front	in	48.3
I	Tread	Rear	in	46.9
J	Wheelbase		in	63
Tire Size	Front	in	165R13-8PR	
	Rear	in	28x8-15-12PR	
Underclearance		in	5.9	

WEIGHTS

Total Weight	w/o Cabin	lb	8910
Weight Distribution	Front	lb	2270
	Rear	lb	6635

ENGINE

Make/Model	Diesel	TOYOTA 1DZ-III
Number of Cylinders		4
Displacement	Cu. In.	152
Rated Horsepower@r.p.m.	SAE HP	53@2400 Net
Rated Torque@r.p.m.	SAE ft-lb	119.3@1800

FUEL SYSTEM

Fuel Tank Capacity - Diesel	US Gal	18
-----------------------------	--------	----

BATTERY

Voltage/Capacity	V/AH	12/64
------------------	------	-------

BRAKE SYSTEM

Brake Type	Front	Disc
	Rear	Drum
System Type	Primary	Tandem Hydraulic
	Parking	Mechanical-Double Action

TRANSMISSION

Transmission	3-Speed Automatic
Shifter	Morse Style

STEERING SYSTEM

Steering Type	Hyd. Power Recirculating Ball
---------------	-------------------------------

TOW HITCH (DRAWBAR)

Single Stage Pin Type Tow Hitch (standard) Double Stage Pin Type Tow Hitch (option)

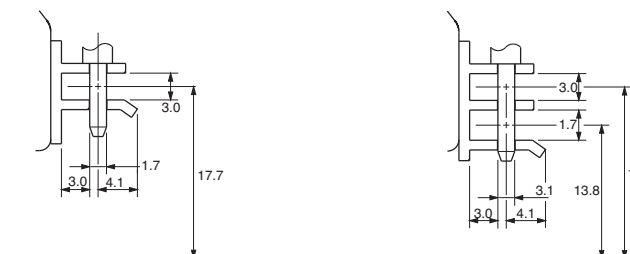

DIMENSIONAL DRAWING

Units: inches

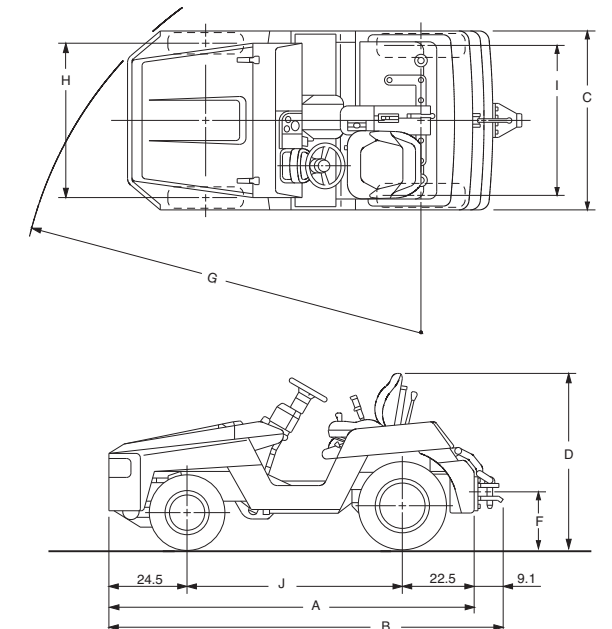

WITH OPTIONAL STEEL CAB

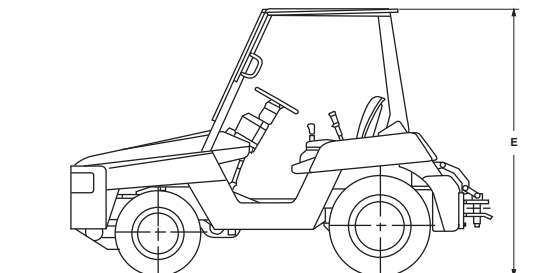

Ramp Degree (°)	Ramp Grade (%)	Level Start with One Trailer (lb)	Start on Grade with One Trailer (lb)
0	0.0	72,752	—
1	1.7	72,752	52,910
2	3.4	72,752	41,887
3	5.2	63,933	35,274
4	6.9	50,706	30,864
5	8.7	41,887	26,455
6	10.5	35,274	22,046
7	12.2	28,660	20,503
8	14.0	24,251	18,078
9	15.8	22,046	16,094
10	17.6	20,062	14,330

Note: Based on dry even concrete (Coefficient of Rolling Resistance = 0.02)
Towed weight is increased by 50% when pulling two or more trailers.